

Feedback Can Increase the Degrees of Freedom of the Rank-Deficient Interference Channel

Sung Ho Chae

Department of Electrical Engineering
KAIST, Daejeon, South Korea
Email: shchae@kaist.ac.kr

Changho Suh

Department of Electrical Engineering
KAIST, Daejeon, South Korea
Email: chsuh@kaist.ac.kr

Sae-Young Chung

Department of Electrical Engineering
KAIST, Daejeon, South Korea
Email: sychung@ee.kaist.ac.kr

Abstract—We characterize the total degrees of freedom (DoF) of the two-user rank-deficient interference channel with feedback, in which transmitter i and receiver j use M_i and N_j antennas, respectively, and the rank of the channel matrix between transmitter i and receiver j is given by $D_{ji} \leq \min(M_i, N_j) \forall i, j = 1, 2$. One consequence of this result is that feedback can increase the DoF when the number of antennas at each node is large enough as compared to the ranks of channel matrices. This finding is in contrast to the full-rank interference channel where feedback provides no DoF gain. The gain comes from using feedback to provide alternative signal paths, thereby effectively increasing the ranks of desired channel matrices.

I. INTRODUCTION

It is well known that feedback cannot increase the capacity of memoryless point-to-point channels [1]. Although the capacity of multiple access channels can in fact increase when feedback is present, the gain is bounded by one bit for the Gaussian case [2]. These results give a pessimistic view on feedback capacity, although feedback can still be useful for simplifying coding strategies as well as improving reliability [3]. Recent work [4], however, has shown that in interference channels, feedback can provide more significant gains. Specifically, it is shown that the capacity gain due to feedback becomes arbitrarily large for certain channel parameters (unbounded gain). The gain comes from the fact that feedback can help efficient resource sharing between the interfering users. In the process of deriving this conclusion, [4] has characterized the feedback capacity region to within 2 bits of the two-user Gaussian interference channel.

The results of [4] indicate that feedback enables a significant capacity improvement of multi-user networks with interfering links. However, if we turn our attention to degrees of freedom (DoF), feedback fails to provide promising results. From the results of [5], [6], it has been shown that feedback cannot improve the total DoF for the two-user full-rank Gaussian MIMO interference channel¹. Therefore, feedback can provide unbounded capacity gain but cannot increase the DoF in the full-rank channel.

In this work, we show that feedback, however, can increase the total DoF in the *rank-deficient* interference channel. The rank-deficient channel captures a poor scattering environment

¹However, recently it has been shown in [7] that for *multihop* networks, feedback can increase DoF.

where there are only few signal paths between nodes. The non-feedback DoF of rank-deficient interference channel has been studied in [8]–[10], and the optimal DoF for the two-user case has been established in [9]. In this paper, we adopt the same rank-deficient channel model as in [9] in which the number of transmit and receive antennas and the ranks of channel matrices are arbitrary. We develop an achievable scheme and also derive a matching upper bound, thus characterizing the total DoF. In consequence of this result, we show that feedback can increase the DoF when the number of antennas at each node is large enough as compared to the ranks of channel matrices. The gain comes from the fact that feedback can provide alternative signal paths in the rank-deficient channel, and hence the ranks of desired channel matrices are effectively increased, which cannot be possible in the full-rank channel. The result of this paper also includes that of full-rank channels with feedback as a special case.

The rest of this paper is organized as follows. In Section II, we describe the channel model considered in this paper. In Section III, we show the main results of the paper and intuitively explain how feedback can increase DoF in the rank-deficient channel. We provide the proof of Theorem 1 in Sections IV and V. Finally, we conclude the paper in Section VI.

Notations: Throughout the paper, we will use \mathbf{A} and \mathbf{a} to denote a matrix and a vector, respectively. Let \mathbf{A}^T and $\|\mathbf{A}\|$ denote the transpose and the norm of \mathbf{A} , respectively. In addition, let $|\mathbf{A}|$ and $\text{rank}(\mathbf{A})$ denote the determinant and the rank of \mathbf{A} , respectively. The notation \mathbf{I}_n denotes the $n \times n$ identity matrix. We write $f(x) = o(x)$ if $\lim_{x \rightarrow \infty} \frac{f(x)}{x} = 0$.

II. SYSTEM MODEL

Consider the rank-deficient interference channel with feedback, as depicted in Fig. 1. We assume that all channel coefficients are fixed and known to all nodes. Then, the input and output relationship at time slot t is given by

$$\mathbf{y}_j(t) = \sum_{i=1}^2 \mathbf{H}_{ji} \mathbf{x}_i(t) + \mathbf{z}_j(t),$$

where $\mathbf{x}_i(t)$ is the $M_i \times 1$ input signal vector at transmitter i , \mathbf{H}_{ji} is the $N_j \times M_i$ channel matrix from transmitter i to receiver j , and $\mathbf{y}_j(t)$ is the $N_j \times 1$ received signal vector

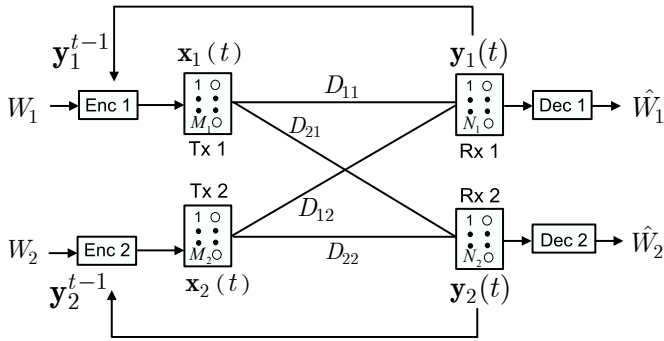

Fig. 1. The rank-deficient interference channel with feedback.

at receiver j . The noise vector $\mathbf{z}_j(t)$ is the additive white circularly symmetric complex Gaussian with zero mean and covariance of \mathbf{I}_{N_j} . We assume that all of the noise vectors and signal vectors are independent of each other.

In this paper, we adopt the rank-deficient channel model in [11], in which there are $D_{ji} \leq \min\{M_i, N_j\}$ independent signal paths from transmitter i to receiver j . Let \mathbf{H}_{ji}^k denote the channel matrix corresponding to the k th signal path. Note that due to the key-hole effect [11], $\text{rank}(\mathbf{H}_{ji}^k) = 1, \forall k = 1, 2, \dots, D_{ji}$. Thus, we assume that the matrix \mathbf{H}_{ji} is given by

$$\begin{aligned} \mathbf{H}_{ji} &= \sum_{k=1}^{D_{ji}} \mathbf{H}_{ji}^k \\ &= \sum_{k=1}^{D_{ji}} \mathbf{a}_{k,j,i} \mathbf{b}_{k,j,i}^T, \forall i, j = 1, 2, \end{aligned} \quad (1)$$

where $\mathbf{a}_{k,j,i}$ and $\mathbf{b}_{k,j,i}$ are $N_j \times 1$ and $M_i \times 1$ vectors respectively, and their coefficients are drawn from a continuous distribution. From (1), we can see that $\text{rank}(\mathbf{H}_{ji}) = D_{ji}$ with probability one.

There are two independent messages W_1 and W_2 . At time slot t , transmitter i sends the encoded signal $\mathbf{x}_i(t)$, which is a function of W_i and past output sequences $\mathbf{y}_i^{t-1} \triangleq [\mathbf{y}_i(1) \ \mathbf{y}_i(2) \ \dots \ \mathbf{y}_i(t-1)]^T$. We assume that each transmitter should satisfy the average power constraint P , i.e., $E[|\mathbf{x}_i(t)|^2] \leq P$ for $i \in \{1, 2\}$. A rate pair (R_1, R_2) is said to be achievable if there exists a sequence of $(2^{nR_1}, 2^{nR_2}, n)$ codes such that the average probability of decoding error tends to zero as the code length n goes to infinity. The capacity region \mathcal{C} of this channel is the closure of the set of achievable rate pairs (R_1, R_2) . The total DoF is defined as $\Gamma = \lim_{P \rightarrow \infty} \max_{(R_1, R_2) \in \mathcal{C}} \frac{R_1 + R_2}{\log(P)}$.

III. MAIN RESULTS

Theorem 1: For the rank-deficient interference channel with feedback, the total DoF is given by

$$\begin{aligned} \Gamma &= \min\{M_1 + N_2 - D_{21}, M_2 + N_1 - D_{12}, \\ &D_{11} + D_{22} + D_{12}, D_{11} + D_{22} + D_{21}, \\ &\min\{M_1, N_1\} + D_{22}, \min\{M_2, N_2\} + D_{11}\} \end{aligned}$$

Proof: See Sections IV and V for the proof. ■

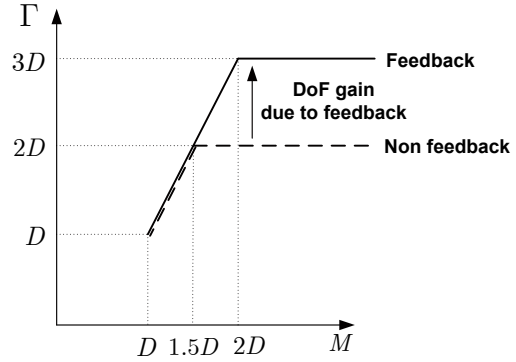
 Fig. 2. Total DoF when $M_1 = M_2 = N_1 = N_2 = M$ and $D_{11} = D_{12} = D_{21} = D_{22} = D$.

Remark 1 (Full-rank case): For the case in which all the channel matrices have full ranks, i.e., $D_{ji} = \min(M_i, N_j) \forall i, j = 1, 2$, the total DoF becomes

$$\Gamma = \min\{M_1 + M_2, N_1 + N_2, \max\{M_1, N_2\}, \max\{M_2, N_1\}\},$$

which coincides with the result for the full-rank interference channel with feedback reported in [5], [6]. ■

Remark 2: If all the direct links have full ranks, i.e., $D_{11} = \min(M_1, N_1)$ and $D_{22} = \min(M_2, N_2)$, the result recovers the non-feedback case in [9]:

$$\Gamma = \min\{M_1 + N_2 - D_{21}, N_1 + M_2 - D_{12}, D_{11} + D_{22}\}. \quad \blacksquare$$

Notice that for the above cases, feedback cannot increase the total DoF.

DoF gain due to feedback: Consider a symmetric case where $M_1 = M_2 = N_1 = N_2 = M$ and $D_{11} = D_{12} = D_{21} = D_{22} = D$. We plot the total DoF as a function of M with fixed D in Fig. 2. Note that the DoF gain due to feedback can be achieved when the ratio of the number of antennas at each node to the rank of each channel matrix is greater than a certain threshold. For $M > 1.5D$, we can achieve a higher DoF. The gain comes from the fact that feedback can provide alternative signal paths when the number of antennas at each node is large enough as compared to the channel ranks.

We first provide an intuition behind this gain through a simple example. We will then prove Theorem 1 later in Sections IV and V.

Example 1: Consider the case where $M_1 = M_2 = N_1 = N_2 = 2$ and $D_{11} = D_{22} = D_{12} = D_{21} = 1$. Our achievable scheme operates in two time slots. See Fig. 3. Let a_i and b_i denote the i th symbols of users 1 and 2, respectively. At time slot 1, transmitter 1 wants to deliver a_1 and a_2 to receivers 1 and 2, respectively. Note that this is feasible since the number of antennas at each node is greater than the rank of each channel matrix such that we can design the transmitted signal for transmitter 1 as

$$\mathbf{x}_1(1) = \mathbf{v}_{1,1}a_1 + \mathbf{v}_{1,2}a_2,$$

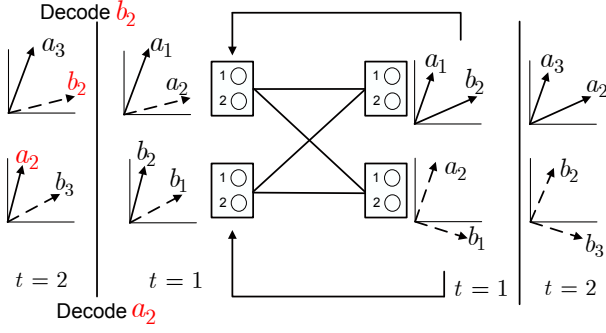

Fig. 3. Achievability in Example 1. The beamforming vectors represented by solid and dashed lines denote the signals transmitted to receivers 1 and 2, respectively.

where $\mathbf{H}_{21}\mathbf{v}_{1,1} = \mathbf{H}_{11}\mathbf{v}_{1,2} = 0$. Similarly, transmitter 2 can forward b_2 and b_1 to receivers 1 and 2, respectively. Then, since channels are generic as (1), the received signals at each receiver are linearly independent of each other with probability one. Therefore, receiver 1 can decode a_1 and transmitter 1 can know b_2 with feedback. Similarly, receiver 2 and transmitter 2 can decode b_1 and a_2 , respectively. Now, at the next time slot, the idea is to send the other user's symbol on top of a new symbol. Receiver 1 can then decode (a_2, a_3) and receiver 2 can decode (b_2, b_3) , as shown in Fig. 3. As a result, six symbols can be transmitted over two time slots, thus $\Gamma \geq 3$ is achievable. Note that the total DoF becomes two when there is no feedback.

Remark 3: From Example 1, we can see that feedback can create new signal paths (e.g., for a_2 , transmitter 1 \rightarrow receiver 2 \rightarrow feedback \rightarrow transmitter 2 \rightarrow receiver 1), which cannot exist in the non-feedback case. When the number of antennas at each node is large enough as compared to the ranks of channel matrices, the dimension of signal space at each node becomes sufficiently large such that some signals can be transmitted through these new signal paths, thus increasing the ranks of effective desired channel matrices. For instance, the effective desired channel matrix for user 1 at time slot 2 is given by $\mathbf{H}_{11}^e = \mathbf{H}_{11} + \mathbf{H}_{12}$, where $\text{rank}(\mathbf{H}_{11}^e) = 2$. However, when all the direct links have full ranks, feedback cannot increase the total DoF since we cannot increase the ranks of direct links further and cannot create such alternative signal paths. Note that the role of feedback here is similar to that of relays in [12], which shows that using multiple relays can create alternative signal paths, thus increasing the total DoF in the rank-deficient interference channel. ■

Remark 4: The main idea of this paper can be extended to general K -user cases. However, a significant distinction is that for $K \geq 3$, feedback also enables *interference alignment* to utilize the dimension of received signals more efficiently. For details, refer to the full-version of this paper [13]. ■

IV. PROOF OF ACHIEVABILITY

As in Example 1, our achievable scheme operates in two time slots. For brevity, we first categorize beamforming vectors for transmitter $i \in \{1, 2\}$ into three types where the notations α , β , and γ are used to denote the signals transmitted to the corresponding receiver only, transmitted to the both receivers, and transmitted to the other receiver only, respectively.

- $\mathbf{v}_{i,k}^\alpha$ denotes the k th beamforming vector for transmitter i such that $\mathbf{H}_{ji}\mathbf{v}_{i,k}^\alpha = 0$ and $\mathbf{H}_{ii}\mathbf{v}_{i,k}^\alpha \neq 0$, where $i \neq j$. Note that since $\text{rank}(\mathbf{H}_{ji}) = D_{ji}$, the maximum number of beamforming vectors satisfying this condition is $M_i - D_{ji}$. Let d_i^α denote the number of these vectors of transmitter i .
- $\mathbf{v}_{i,k}^\beta$ denotes the k th beamforming vector for transmitter i whose coefficients are drawn from a continuous distribution and $0 < \|\mathbf{v}_{i,k}^\beta\| \leq A$, where A is a finite value. Hence, $\mathbf{H}_{ii}\mathbf{v}_{i,k}^\beta \neq 0$ and $\mathbf{H}_{ji}\mathbf{v}_{i,k}^\beta \neq 0$ with probability one. Let d_i^β denote the number of these vectors of transmitter i .
- $\mathbf{v}_{i,k}^\gamma$ denotes the k th beamforming vector for transmitter i such that $\mathbf{H}_{ii}\mathbf{v}_{i,k}^\gamma = 0$ and $\mathbf{H}_{ji}\mathbf{v}_{i,k}^\gamma \neq 0$. Note that since $\text{rank}(\mathbf{H}_{ii}) = D_{ii}$, the maximum number of beamforming vectors satisfying this condition is $M_i - D_{ii}$. Let d_i^γ denote the number of these vectors of transmitter i .

Now we explain the proposed scheme. Let a_i and b_i denote the i th symbols of users 1 and 2, respectively. In addition, let $\mathbf{s}_i^\delta(1)$ denote the symbols of user i conveyed by $\mathbf{v}_{i,k}^\delta$ at time slot 1, where $\delta \in \{\alpha, \beta, \gamma\}$. Specifically, the symbols of user 1 are categorized as

$$\begin{aligned} \mathbf{s}_1^\alpha(1) &= [a_1 \ a_2 \ \cdots \ a_{d_1^\alpha}]^T \\ \mathbf{s}_1^\beta(1) &= [a_{d_1^\alpha+1} \ a_{d_1^\alpha+2} \ \cdots \ a_{d_1^\alpha+d_1^\beta}]^T \\ \mathbf{s}_1^\gamma(1) &= [a_{d_1^\alpha+d_1^\beta+1} \ a_{d_1^\alpha+d_1^\beta+2} \ \cdots \ a_{d_1^\alpha+d_1^\beta+d_1^\gamma}]^T. \end{aligned}$$

Similarly, the symbols of user 2 are categorized as

$$\begin{aligned} \mathbf{s}_2^\alpha(1) &= [b_1 \ b_2 \ \cdots \ b_{d_2^\alpha}]^T \\ \mathbf{s}_2^\beta(1) &= [b_{d_2^\alpha+1} \ b_{d_2^\alpha+2} \ \cdots \ b_{d_2^\alpha+d_2^\beta}]^T \\ \mathbf{s}_2^\gamma(1) &= [b_{d_2^\alpha+d_2^\beta+1} \ b_{d_2^\alpha+d_2^\beta+2} \ \cdots \ b_{d_2^\alpha+d_2^\beta+d_2^\gamma}]^T. \end{aligned}$$

At the first time slot, we design the transmitted signal for transmitter $i \in \{1, 2\}$ as

$$\begin{aligned} \mathbf{x}_i(1) &= [\mathbf{V}_i^\alpha \ \mathbf{V}_i^\beta \ \mathbf{V}_i^\gamma] \begin{bmatrix} \mathbf{s}_i^\alpha(1) \\ \mathbf{s}_i^\beta(1) \\ \mathbf{s}_i^\gamma(1) \end{bmatrix} \\ &= \mathbf{V}_i^\alpha \mathbf{s}_i^\alpha(1) + \mathbf{V}_i^\beta \mathbf{s}_i^\beta(1) + \mathbf{V}_i^\gamma \mathbf{s}_i^\gamma(1), \end{aligned}$$

where

$$\begin{aligned} \mathbf{V}_i^\alpha &= [\mathbf{v}_{i,1}^\alpha \ \cdots \ \mathbf{v}_{i,d_1^\alpha}^\alpha] \\ \mathbf{V}_i^\beta &= [\mathbf{v}_{i,d_1^\alpha+1}^\beta \ \cdots \ \mathbf{v}_{i,d_1^\alpha+d_1^\beta}^\beta] \\ \mathbf{V}_i^\gamma &= [\mathbf{v}_{i,d_1^\alpha+d_1^\beta+1}^\gamma \ \cdots \ \mathbf{v}_{i,d_1^\alpha+d_1^\beta+d_1^\gamma}^\gamma]. \end{aligned}$$

Here, transmitters send their symbols with independent Gaussian signaling, i.e.,

$$\mathbf{s}_i(1) = \begin{bmatrix} \mathbf{s}_i^\alpha(1) \\ \mathbf{s}_i^\beta(1) \\ \mathbf{s}_i^\gamma(1) \end{bmatrix} \sim \mathcal{CN}\left(\mathbf{0}_d, \frac{P}{d}\mathbf{I}_d\right)$$

where $d = d_i^\alpha + d_i^\beta + d_i^\gamma$, and \mathbf{V}_i^α , \mathbf{V}_i^β , and \mathbf{V}_i^γ are properly scaled to satisfy the power constraint P . Then the received signal at receiver $i \in \{1, 2\}$ is given by

$$\begin{aligned} \mathbf{y}_i(1) &= \mathbf{H}_{ii}\mathbf{x}_i(1) + \mathbf{H}_{ij}\mathbf{x}_j(1) + \mathbf{z}_i(1) \\ &= \mathbf{H}_{ii}\mathbf{V}_i^\alpha\mathbf{s}_i^\alpha(1) + \mathbf{H}_{ii}\mathbf{V}_i^\beta\mathbf{s}_i^\beta(1) \\ &\quad + \mathbf{H}_{ij}\mathbf{V}_j^\beta\mathbf{s}_j^\beta(1) + \mathbf{H}_{ij}\mathbf{V}_j^\gamma\mathbf{s}_j^\gamma(1) + \mathbf{z}_i(1). \end{aligned} \quad (2)$$

In the proposed scheme, we want to enable receiver i to decode its desired symbols $\mathbf{s}_i^\alpha(1)$ and $\mathbf{s}_i^\beta(1)$. In addition, we also want to make transmitter i be able to know the other user's symbols $\mathbf{s}_j^\beta(1)$ and $\mathbf{s}_j^\gamma(1)$ after its corresponding receiver feeds back the received signal. To achieve these, we choose $d_1^\alpha, d_1^\beta, d_1^\gamma, d_2^\alpha, d_2^\beta$, and d_2^γ to satisfy the following conditions.

$$d_1^\gamma = d_2^\gamma \triangleq d^f \quad (3)$$

$$0 \leq d_1^\alpha \leq M_1 - D_{21} \quad (4)$$

$$0 \leq d_2^\alpha \leq M_2 - D_{12} \quad (5)$$

$$0 \leq d^f \leq \min\{M_1 - D_{11}, M_2 - D_{22}\} \quad (6)$$

$$0 \leq d_1^\alpha + d_1^\beta \leq D_{11} \quad (7)$$

$$0 \leq d_2^\alpha + d_2^\beta \leq D_{22} \quad (8)$$

$$0 \leq d_1^\beta + d^f \leq D_{21} \quad (9)$$

$$0 \leq d_2^\beta + d^f \leq D_{12} \quad (10)$$

$$0 \leq d_1^\beta + d^f + d_2^\alpha + d_2^\beta \leq N_2 \quad (11)$$

$$0 \leq d_2^\beta + d^f + d_1^\alpha + d_1^\beta \leq N_1 \quad (12)$$

Here, the conditions (4)-(6) are due to the properties of $\mathbf{v}_{i,k}^\alpha$ and $\mathbf{v}_{i,k}^\gamma$; (7)-(10) are due to the fact that the number of symbols transmitted through a channel is constrained by the rank of the channel matrix; (11)-(12) are due to the fact that the number of received symbols at a receiver should be less than or equal to the number of antennas at the receiver. Note that if the above conditions are satisfied, we have

$$\begin{aligned} \text{rank}\left(\begin{bmatrix} \mathbf{H}_{ii}[\mathbf{V}_i^\alpha & \mathbf{V}_i^\beta] & \mathbf{H}_{ij}[\mathbf{V}_j^\beta & \mathbf{V}_j^\gamma] \end{bmatrix}\right) \\ = d_1^\alpha + d_i^\beta + d_j^\beta + d^f. \end{aligned}$$

with probability one $\forall i = 1, 2$ and $i \neq j$. This is due to the facts that $\begin{bmatrix} \mathbf{V}_i^\alpha & \mathbf{V}_i^\beta & \mathbf{V}_i^\gamma \end{bmatrix}$ is a full-rank matrix $\forall i = 1, 2$ and channel matrices are generic so that \mathbf{H}_{ii} and \mathbf{H}_{ij} are random linear transformations. In addition, since $d_i^\alpha + d_i^\beta \leq D_{ii}$ and $d_j^\beta + d^f \leq \min\{D_{12}, D_{21}\}$, linear independence of signals is also preserved. Thus, we can see that by observing $\mathbf{y}_i(1)$ in (2), receiver i and transmitter i can obtain the desired results by zero-forcing. Consequently, at time slot 1, receivers 1 and 2 can decode $d_1^\alpha + d_1^\beta$ and $d_2^\alpha + d_2^\beta$ symbols, respectively.

Now we consider the proposed scheme in the second time slot. Recall that transmitter i can know the other user's

symbols $\mathbf{s}_j^\beta(1)$ and $\mathbf{s}_j^\gamma(1)$ after receiving feedback signal $\mathbf{y}_i(1)$. Among these symbols, transmitter i sends only $\mathbf{s}_j^\gamma(1)$ for receiver j at the next time slot since symbols of $\mathbf{s}_j^\beta(1)$ were already decoded by receiver j at the first time slot. Thus, at the second time slot, we design the transmitted signal for transmitter $i \in \{1, 2\}$ as

$$\mathbf{x}_i(2) = \mathbf{V}_i^\alpha\mathbf{s}_i^\alpha(2) + \mathbf{V}_i^\beta\mathbf{s}_i^\beta(2) + \mathbf{V}_i^\gamma\mathbf{s}_j^\gamma(1),$$

where

$$\begin{aligned} \mathbf{s}_1^\alpha(2) &= \begin{bmatrix} a_{d_1^\alpha + d_1^\beta + d_1^\gamma + 1} & \cdots & a_{2d_1^\alpha + d_1^\beta + d_1^\gamma} \end{bmatrix}^T \\ \mathbf{s}_1^\beta(2) &= \begin{bmatrix} a_{2d_1^\alpha + d_1^\beta + d_1^\gamma + 1} & \cdots & a_{2d_1^\alpha + 2d_1^\beta + d_1^\gamma} \end{bmatrix}^T \\ \mathbf{s}_2^\alpha(2) &= \begin{bmatrix} b_{d_2^\alpha + d_2^\beta + d_2^\gamma + 1} & \cdots & b_{2d_2^\alpha + d_2^\beta + d_2^\gamma} \end{bmatrix}^T \\ \mathbf{s}_2^\beta(2) &= \begin{bmatrix} b_{2d_2^\alpha + d_2^\beta + d_2^\gamma + 1} & \cdots & b_{2d_2^\alpha + 2d_2^\beta + d_2^\gamma} \end{bmatrix}^T. \end{aligned}$$

Here, $\mathbf{s}_i^\alpha(2)$ and $\mathbf{s}_i^\beta(2)$ are new symbols of user i transmitted at the second time slot. As a result, the received signal at receiver $i \in \{1, 2\}$ is given by

$$\begin{aligned} \mathbf{y}_i(2) &= \mathbf{H}_{ii}\mathbf{x}_i(2) + \mathbf{H}_{ij}\mathbf{x}_j(2) + \mathbf{z}_i(2) \\ &= \mathbf{H}_{ii}\mathbf{V}_i^\alpha\mathbf{s}_i^\alpha(2) + \mathbf{H}_{ii}\mathbf{V}_i^\beta\mathbf{s}_i^\beta(2) \\ &\quad + \mathbf{H}_{ij}\mathbf{V}_j^\beta\mathbf{s}_j^\beta(2) + \mathbf{H}_{ij}\mathbf{V}_j^\gamma\mathbf{s}_j^\gamma(1) + \mathbf{z}_i(2). \end{aligned}$$

Then, using the same argument as above, we can see that receiver i can decode all the symbols $\mathbf{s}_i^\alpha(2)$, $\mathbf{s}_i^\beta(2)$, and $\mathbf{s}_i^\gamma(1)$.

In summary, during two time slots, receivers 1 and 2 can decode $2d_1^\alpha + 2d_1^\beta + d_1^\gamma$ and $2d_2^\alpha + 2d_2^\beta + d_2^\gamma$ symbols, respectively. Therefore, the achievable total DoF is given by

$$\begin{aligned} \Gamma &\geq d_1^\alpha + d_1^\beta + d_2^\alpha + d_2^\beta + \frac{d_1^\gamma + d_2^\gamma}{2} \\ &= d_1^\alpha + d_1^\beta + d_2^\alpha + d_2^\beta + d^f. \end{aligned}$$

Finally, by evaluating the conditions (3)-(12) using the Fourier-Motzkin elimination, we can obtain the desired bound:

$$\begin{aligned} \Gamma &\geq \min\{M_1 + N_2 - D_{21}, M_2 + N_1 - D_{12}, \\ &\quad D_{11} + D_{22} + D_{12}, D_{11} + D_{22} + D_{21}, \\ &\quad \min\{M_1, N_1\} + D_{22}, \min\{M_2, N_2\} + D_{11}\}. \end{aligned}$$

Remark 5: The achievable total DoF can also be established in an alternative way. One implicit strategy is to employ Lemma 1 in [4]. We can achieve the same DoF by setting $X_i = U_{if} + U_i + X_{ip}$ where $U_{if} = \mathbf{V}_i^\gamma\mathbf{s}_i^\gamma(1)$, $U = (U_{1f}, U_{2f})$, $U_i = \mathbf{V}_i^\beta\mathbf{s}_i^\beta(1)$, and $X_{ip} = \mathbf{V}_i^\alpha\mathbf{s}_i^\alpha(1)$, $\forall i = 1, 2$. ■

V. PROOF OF CONVERSE

The proof is a direct extension of that in the two-user SISO interference channel with feedback [4]. Hence, we focus on explaining the steps needed for rank-deficient channels.

Starting with Fano's inequality, we get:

$$\begin{aligned} n(R_1 + R_2 - \epsilon_n) &\leq I(W_1; \mathbf{y}_1^n) + I(W_2; \mathbf{y}_2^n) \\ &\leq I(W_1; \mathbf{y}_1^n, \mathbf{s}_1^n, W_2) + I(W_2; \mathbf{y}_2^n) \end{aligned}$$

where $\mathbf{s}_1(t) = \mathbf{H}_{21}\mathbf{x}_1(t) + \mathbf{z}_2(t)$ as in [4]. Hence, by following the same steps in [4], we have

$$R_1 + R_2 \leq h(\mathbf{y}_2) + h(\mathbf{y}_1|\mathbf{s}_1, \mathbf{x}_2) - h(\mathbf{z}_1) - h(\mathbf{z}_2). \quad (13)$$

Now we evaluate the inequality (13) with respect to the number of antennas at each node and the rank of each channel matrix. From (13), we have

$$\begin{aligned} R_1 + R_2 &\leq h(\mathbf{y}_2) + h(\mathbf{y}_1|\mathbf{s}_1, \mathbf{x}_2) - h(\mathbf{z}_1) - h(\mathbf{z}_2) \\ &\leq h(\mathbf{y}_2) + h(\mathbf{H}_{11}\mathbf{x}_1 + \mathbf{z}_1|\mathbf{s}_1) - h(\mathbf{z}_1) - h(\mathbf{z}_2). \end{aligned}$$

Notice that

$$\begin{aligned} h(\mathbf{y}_2) - h(\mathbf{z}_2) &\leq \log |K_{\mathbf{y}_2}^G| \\ h(\mathbf{H}_{11}\mathbf{x}_1 + \mathbf{z}_1|\mathbf{s}_1) - h(\mathbf{z}_1) &\leq \log \frac{|K_{(\mathbf{H}_{11}\mathbf{x}_1 + \mathbf{z}_1, \mathbf{s}_1)}^G|}{|K_{\mathbf{s}_1}^G|}, \end{aligned}$$

where $K_{\mathbf{x}}^G$ denotes the covariance matrix of a Gaussian random vector \mathbf{x} [3], [14]. Straightforward computation gives

$$\begin{aligned} \log |K_{\mathbf{y}_2}^G| &\leq \min\{N_2, D_{22} + D_{21}\} \log P + o(\log P) \\ \log \frac{|K_{(\mathbf{H}_{11}\mathbf{x}_1 + \mathbf{z}_1, \mathbf{s}_1)}^G|}{|K_{\mathbf{s}_1}^G|} &\leq \min\{M_1 - D_{21}, D_{11}\} \log P \\ &\quad + o(\log P). \end{aligned}$$

Therefore, we have

$$\begin{aligned} \Gamma &\leq \min\{N_2, D_{22} + D_{21}\} + \min\{M_1 - D_{21}, D_{11}\} \\ &= \min\{N_2 + M_1 - D_{21}, N_2 + D_{11}, \\ &\quad M_1 + D_{22}, D_{22} + D_{21} + D_{11}\}. \end{aligned} \quad (14)$$

By symmetry, we can also get the following upper bound:

$$\begin{aligned} \Gamma &\leq \min\{N_1 + M_2 - D_{12}, N_1 + D_{22}, \\ &\quad M_2 + D_{11}, D_{11} + D_{12} + D_{22}\}. \end{aligned} \quad (15)$$

Combining (14) and (15), we can obtain the desired bound:

$$\begin{aligned} \Gamma &\leq \min\{M_1 + N_2 - D_{21}, M_2 + N_1 - D_{12}, \\ &\quad D_{11} + D_{22} + D_{12}, D_{11} + D_{22} + D_{21}, \\ &\quad \min\{M_1, N_1\} + D_{22}, \min\{M_2, N_2\} + D_{11}\}. \end{aligned}$$

VI. CONCLUSION

In this paper, we have characterized the total degrees of freedom (DoF) of the two-user rank-deficient interference channel with feedback, by developing an achievable scheme and deriving a matching upper bound. One interesting consequence of this result is that feedback can indeed increase the DoF in contrast to the full-rank case. The gain comes from the fact that feedback can provide alternative signal paths when the number of antennas at each node is large enough as compared to the channel ranks, thus increasing the ranks of effective desired channel matrices.

ACKNOWLEDGMENT

S. H. Chae and S.-Y. Chung were supported in part by the MSIP under the ITRC program (NIPA-2013-(H0301-13-1005)). C. Suh was funded by the MSIP, Korea in the ICT R&D Program 2013.

REFERENCES

- [1] C. E. Shannon, "The zero error capacity of a noisy channel," *IRE Transactions on Information Theory*, Sept. 1956.
- [2] L. H. Ozarow, "The capacity of the white Gaussian multiple access channel with feedback," *IEEE Trans. Inf. Theory*, vol. 30, no. 4, pp. 623–629, July 1984.
- [3] A. El Gamal and Y.-H. Kim, *Lecture Notes on Network Information Theory*, 2010.
- [4] C. Suh and D. Tse, "Feedback capacity of the Gaussian interference channel to within 2 bits," *IEEE Trans. Inf. Theory*, vol. 57, pp. 2667–2685, May 2011.
- [5] C. Huang and S. A. Jafar, "Degrees of freedom of the MIMO interference channel with cooperation and cognition," *IEEE Trans. Inf. Theory*, vol. 55, no. 9, pp. 4211–4220, Sept. 2009.
- [6] C. S. Vaze and M. K. Varanasi, "The degrees of freedom region of the MIMO interference channel with Shannon feedback," [Online]. Available: <http://arxiv.org/abs/1109.5779>, Oct. 2011.
- [7] I.-H. Wang and C. Suh, "Feedback increases the degrees of freedom of two unicast Gaussian networks," in *Proc. 50th Annu. Allerton Conf. Communication, Control, and Computing*, Monticello, IL, Oct. 2012.
- [8] S. H. Chae and S.-Y. Chung, "On the degrees of freedom of rank deficient interference channels," in *Proc. IEEE International Symposium on Information Theory*, Saint Petersburg, Russia, Jul.-Aug. 2011, pp. 1367–1371.
- [9] S. R. Krishnamurthy and S. A. Jafar, "Degrees of freedom of 2-user and 3-user rank-deficient MIMO interference channels," in *Proc. 2012 IEEE Global Telecommunications Conference (GLOBECOM)*, Anaheim, USA, Dec. 2012.
- [10] Y. Zeng, X. Xu, Y. L. Guan, and E. Gunawan, "On the achievable degrees of freedom for the 3-user rank-deficient MIMO interference channel," [Online]. Available: <http://arxiv.org/abs/1211.4198>, Nov. 2012.
- [11] D. Tse and P. Viswanath, *Fundamentals of Wireless communication*. Cambridge University Press, 2005.
- [12] S. H. Chae, S.-W. Jeon, and S.-Y. Chung, "Cooperative relaying for the rank-deficient MIMO relay interference channel," *IEEE Commun. Lett.*, vol. 16, no. 1, pp. 9–11, Jan. 2012.
- [13] S. H. Chae, C. Suh, and S.-Y. Chung, "Degrees of freedom of rank-deficient interference channels with feedback," in preparation.
- [14] D. S. Papailiopoulos, C. Suh, and A. G. Dimakis, "Feedback in the K -user interference channel," in *Proc. IEEE International Symposium on Information Theory*, Cambridge, MA, Jul. 2012, pp. 3130–3134.